

SHD-E

“Standard” Hopper Dryer

Date: Dec., 2022

Version: Ver. C



Content

1. General Description	6
1.1 Coding Principle.....	7
1.2 Feature	7
1.2.1 Options	7
1.3 Safety Regulations.....	10
1.3.1 Safety Signs and Labels.....	10
1.3.2 Sign and Labels.....	10
1.4 Exemption Clause.....	11
2. Structure Characteristics and Working Principle	12
2.1 Working Principle	12
2.2 Options (Purchased Separately)	13
2.2.1 Magnetic Base.....	13
2.2.2 Hot Air Recycler.....	13
2.2.3 Air Filter	13
2.2.4 Blower Inlet Filter.....	14
2.2.5 Hopper Magnet.....	14
2.2.6 European Suction Box/Shut-off Suction Box	14
2.2.7 N-Type Floor Stand	15
3. Installation and Debugging.....	16
3.1 Direct Installation	16
3.2 Power Connection.....	16
3.3 The Hopper Dryer Test	17
3.4 Installation of the Options	18
3.4.1 Installation of Air-Exhaust Filter.....	18
3.4.2 Suction Box Installation	19
3.4.3 Blower Inlet Filter Installation.....	19
3.4.4 Hot Air Recycler Installation	20
4. Operation Guide	21
4.1 Control Panel	21
4.1.1 Panel Operation	21
4.1.2 Temperature Setting.....	21

4.1.3	Temperature Lock	21
4.1.4	PID Setting	22
4.1.5	Intermittent Operation Setting.....	23
4.1.6	One-week Timing Setting	23
4.1.7	Communication Setting (optional functions)	23
4.1.8	Operation Flow	25
4.1.9	Wrong Codes Remark	26
5.	Maintenance and Repair	27
5.1	Blower.....	27
6.	Troubleshooting	28

Table Index

Table 1-1:	Dryer drying capacity (kg/hr) (Selection guide).....	9
Table 1-2:	Label Description	10
Table 2-1:	Configuration Table.....	13
Table 2-2:	Configuration Table.....	13
Table 2-3:	Configuration Table.....	14
Table 2-4:	Configuration Table.....	14
Table 4-1:	PID Setting Parameter	23
Table 4-2:	Communication Setting Parameter	24
Table 4-3:	Error Code Description.....	26
Table 6-1:	Common Faults and Troubleshootings	28

Picture Index

Picture 1-1:	SHD-50E.....	6
Picture 2-1	Working principle	12
Picture 3-1:	Direct Installation	16
Picture 3-2:	Blower	18
Picture 3-3:	Left: Air-exhaust elbow of dryer Right: Air-exhaust filter.....	18
Picture 3-4:	European suction box	19
Picture 3-5:	Shut-off suction box	19

Picture 3-6: Right: AIF blower inlet filter.....	19
Picture 3-7: HAR Hot air recycler	20
Picture 4-1: Control Panel	21

1. General Description



Please read through this operation manual before using the machine to prevent damages of the machine or personal injuries.



Picture 1-1: SHD-50E

1.1 Coding Principle

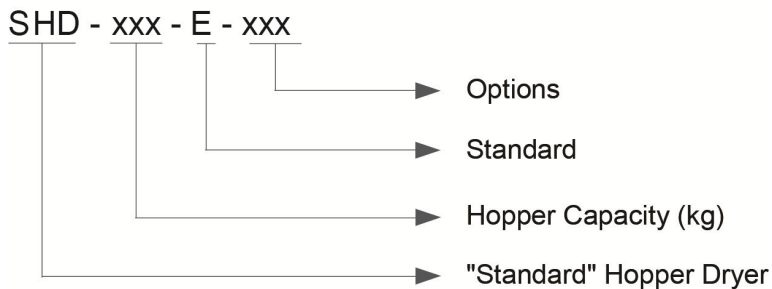

1.2 Feature

- 1) Adopt hot air diffuser to keep plastics dry and temperature stable, thus improve drying efficiency.
- 2) All material contact surfaces are made of stainless steel to eliminate material contamination.
- 3) All models are equipped with external power switch.
- 4) For SHD-25~150, heater pipes are connected by lead sheets and other models are equipped with temperature protector to prevent heater pipe from damaging by blower fault.
- 5) When the actual drying temp. exceeds the set value, the system will cut off the heater power automatically, and the alarm light will flicker and alarm.
- 6) Adopt heat-insulated blower to prolong blower lifespan.
- 7) All models standard equipped with 7-day timer and intermittent operation
- 8) The whole series of models are equipped with the microcomputer control.
- 9) Max. drying temperature is 160°C.
- 10) The series of blowers are equipped with overheat protector.

1.2.1 Options

- 1) For high temp. (180°C) models, add "H" at the end of the model code (applicable to SHD-12E~200E)
- 2) The option of magnetic base is available, add "M" at the end of the model code.
- 3) Optional RS485 interface is available, add "C" at the end of the model code.
- 4) For models optional with 24V microcomputer, RS485 interface and three color alarm light, add "A" at the end of the model code.

The option of insulated hopper is available, add "I" at the end of the model code.

All service work should be carried out by a person with technical training or corresponding professional experience. The manual contains instructions for both handling and servicing. Chapter 5, which contains service instructions intended for service engineers. Other chapters contain instructions for the daily operator.

Any modifications of the machine must be approved by SHINI in order to avoid personal injury and damage to machine. We shall not be liable for any damage caused by unauthorized change of the machine.

Our company provides excellent after-sales service. Should you have any problem during using the machine, please contact the company or the local vendor.

Shini Hotline Service:

Headquarter and Taipei factory:

Tel: + 886 (0)2 2680 9119

Shini Plastics Technologies (Dongguan), Inc.:

Tel: +86 (0)769 8331 3588

Shini Plastics Technologies (Pinghu), Inc.:

Tel: +86 (0)573 8522 5288

Shinden Precision Machinery (Chongqing), Inc.:

+86 (0)23 6431 0898

Table 1-1: Dryer drying capacity (kg/hr) (Selection guide)

Mo del Material	SHD-12E	SHD-25E	SHD-50E	SHD-75E	SHD-100E	SHD-150E	SHD-200E	SHD-300E	SHD-400E	Actual Drying Time	Drying Temp.
Polystyrene	8	20	50	75	100	150	200	300	400	0.75hrs	80°C
Polyethylene	8	20	50	75	100	150	200	300	400	0.75hrs	80°C
Polypropylene	8	20	50	75	100	150	200	300	400	0.75hrs	80°C
Poly styrene (EPR)	6	14	38	57	80	115	150	225	300	1hrs	80°C
ABS	4	8	20	30	40	60	80	120	160	1hrs	80°C
Nylon (Nylon)11,12	2	4	10	13	20	27	35	60	80	4hrs	75°C
(Nylon)6/6,6/10	1.5	3.2	8	11	16	22	30	45	65	5hrs	75°C
(Nylon) 6	1	2	5	7	10	15	20	35	50	7hrs	75°C
Acrylic fiber	2.5	6	12	22	30	45	60	100	140	2.5hrs	80°C
Cellulose acetate	2.5	6	17	26	35	52	70	110	150	2.25hrs	75°C
Butyrate	4	10	25	37	50	75	100	160	220	1.5hrs	-
Polycarbonate	1.5	4	10	15	20	30	40	75	90	3hrs	120°C
Rigid PVC	5	12	30	45	60	90	120	185	250	1.25hrs	70°C

Notes:Based on relative humidity 65% with ambient temperature of 20°C,moisure content after drying can be 0.2% ro less.

1.3 Safety Regulations



Note:

Electrical installation should be done by qualified electrician only.

Before connecting to AC Power Source, turn power switch to OFF position. While AC power source is connected, make sure specifications and overload protection rating of the power switch are suitable and reliable. When the machine is under care or maintenance, turn off both power switch and automatic operation switch.

1.3.1 Safety Signs and Labels



Danger!

High pressure!

It is attached to the control box.



Warning!

High temperature surface may burn hands!

It is attached on the cover of pipe heater.



Attention!

This mark reminds you to be more careful!



Warning!

High temperature surface may burn hands!

This label should be stick to the shell of electric heating box.

1.3.2 Sign and Labels

Table 1-2: Label Description

Label	Description
<p>↑ 超溫時，保護裝置動作；解除故障後，按藍色鍵復位並合上開關，重新通電運行。 Protection device activates when overheat occurs; after faults are discharged, press blue key to reset and turn on the switch to restart operation. 超溫保護裝置 Overheat protection device</p>	<p>Protection device activates when overheat occurs; After faults are discharged,press blue key to reset and turn on the switch to restart.</p>

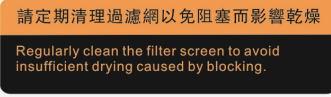
	<p>Push-and-pull switch for shut-off plate:</p> <p>I: Means "Pull"</p> <p>O: Means "Push"</p>
	<p>Regularly clean the filter screen to avoid insufficient drying caused by blocking.</p>

1.4 Exemption Clause

The following statements clarify the responsibilities and regulations born by any buyer or user who purchases products and accessories from Shini (including employees and agents).

Shini is exempted from liability for any costs, fees, claims and losses caused by reasons below:

1. Any careless or man-made installations, operation and maintenances upon machines without referring to the Manual prior to machine using.
2. Any incidents beyond human reasonable controls, which include man-made vicious or deliberate damages or abnormal power, and machine faults caused by irresistible natural disasters including fire, flood, storm and earthquake.
3. Any operational actions that are not authorized by Shini upon machine, including adding or replacing accessories, dismantling, delivering or repairing.
4. Employing consumables or oil media that are not appointed by Shini.

2. Structure Characteristics and Working Principle

2.1 Working Principle

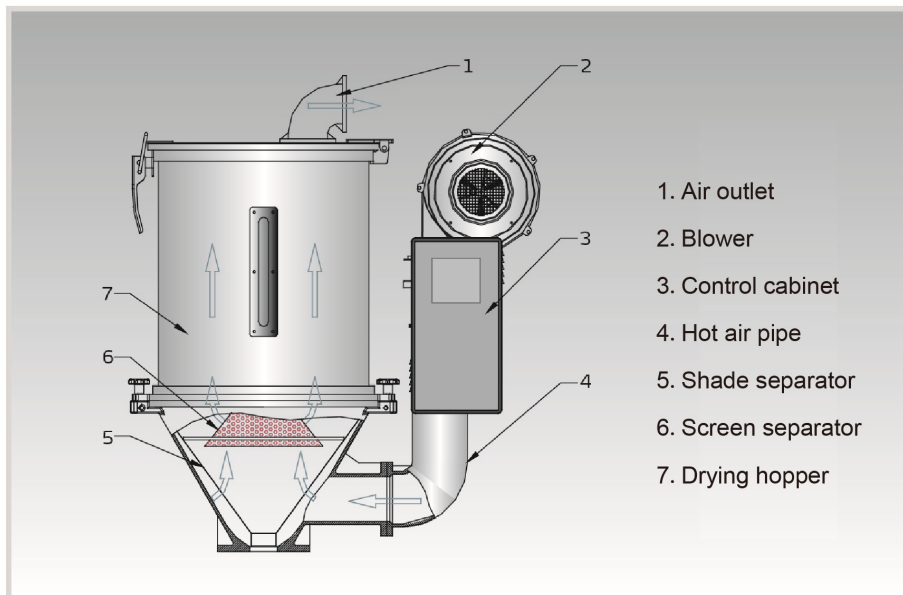

Picture 2-1 Working principle

In the drying process, hot air with constant temperature is blown by the drying blower of SHD-E. After drying, moisture will be separated out and taken away by hot air, thus to gain a satisfied drying effect. Air blown out of blower via pipe heater became high temperature drying air after being heated. Through shade separator and screen protector, hot air can be evenly dispersed to the material in drying hopper (see picture). Hot air recycler is optional so the air entered drying blower after being filtered by return air will get into the drying blower to form a closed loop circle, which saves electricity.

2.2 Options (Purchased Separately)

2.2.1 Magnetic Base

Table 2-1: Configuration Table



Model	Applied to
MB-12EB	SHD-12E
MB-50	SHD-25E~75E
MB-100EB	SHD-100E~150E
MB-200EB	SHD-200E~300E
MB-400EB	SHD-400E

Made of aluminum with built-in hopper magnet, can effectively separate metal scraps out to avoid material contamination and protect the screw.

2.2.2 Hot Air Recycler

Table 2-2: Configuration Table



Model	Filtering Barrel Dia. (mm)	Inlet Air Pipe Dia. (inch)	Flange of Air Outlet (inch)	Applied to
HAR-12	157	2		SHD-12E
HAR-25EB	157	2.5		SHD-25E
HAR-50	177	3		SHD-50E/75E
HAR-100EB	219	3		SHD-100E/150E
HAR-200EB	249	4		SHD-200E/300E
HAR-400EB	221	4		SHD-400E

Work with hopper dryer to make the hot air form a semi-closed circulated loop and has features as follows:

- 5) Hot air recycling and circulating avoids indoor temperature rising up.
- 6) Keep air in factory clean and ensure good product quality.
- 7) Heating by fast hot air circulation can lower energy consumption by 40%.

2.2.3 Air Filter

Table 2-3: Configuration Table



Model	Applied to
ADC-1	SHD-12E
ADC-2	SHD-25E~150E
ADC-3EB	SHD-200E ~400E

Effectively filter 99% of dust-contain air discharged from dryer to avoid air pollution.

2.2.4 Blower Inlet Filter

Table 2-4: Configuration Table



Model	Filtering Barrel Dia. (mm)	Overall height (mm)	Applied to
AIF-12	157	195	SHD-12E
AIF-25EB	157	195	SHD-25E
AIF-50	177	201	SHD-50E/75E
AIF-100EB	219	191	SHD-100E/150E
AIF-200EB	249	268	SHD-200E~300E
AIF-400EB	221	380	SHD-400E

Notes: refill air input of the blower is adjustable.

2.2.5 Hopper Magnet



Model	Applied to
MR-5	SHD-12E
MR-7	SHD-25E/50E/75E
MR-9	SHD-100E/150E/200E/300E/400E

Absorb metal scraps in the material to avoid the damage of molding screw.

2.2.6 European Suction Box/Shut-off Suction Box

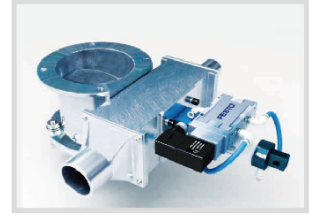

Model \ Applied	SHD-12E~75E	SHD-100E~400E
SBU	-20-38S	-160-38S
SBU	-20-50S	-160-50S
SBU	-20-38D	-160-38D
SBU	-20-50D	-160-50D

- Notes: 1) Install pneumatic shut-off valve (Add "V" at the end of the model code.)
 2) Change into stainless steel material (Add "S" at the end of the model code.)
 3) Stainless steel polishing (Add "P" at the end of the model code.)
 4) "S" stands for single tube suction box and "D" stands for double tubes suction box.
 5) It must use with the floor stand.

2.2.7 N-Type Floor Stand

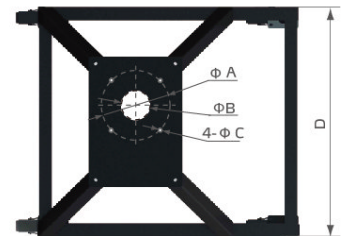
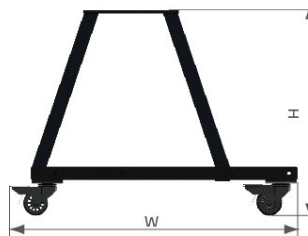

Model	Applied to	Dimension H×W×D(mm)	A / B / C (mm)
FSN-50	SHD-12E~75E	600×700×640	140/54/ 9
FSN-100	SHD-100E/150E	615×800×710	210/90/11
FSN-200	SHD-200E/300E	680×1000×840	210/90/11
FSN-400	SHD-400E~600E	700×1200×1010	260/116 /13

With which machines can be easily moved out of workplace which is suitable for the factories with height limited workshops and also it can make operations more convenient. The N-type floor stand can replace any machine that is applicable to the SHD-E series.

3. Installation and Debugging

Notes for Installation and Positioning:

- 1) Machine just can be mounted in vertical position. Make sure there's no pipe, fixed structure or other objects above the installing location and around the machine which may block machine's installation, hit objects or injure human person.
- 2) In order to maintain convenient operation, it's suggested to keep 1m space around the machine. Please keep at least 2m distance between the device and the inflammable goods.
- 3) This series of models only could be applied in working environment with good ventilation.

3.1 Direct Installation

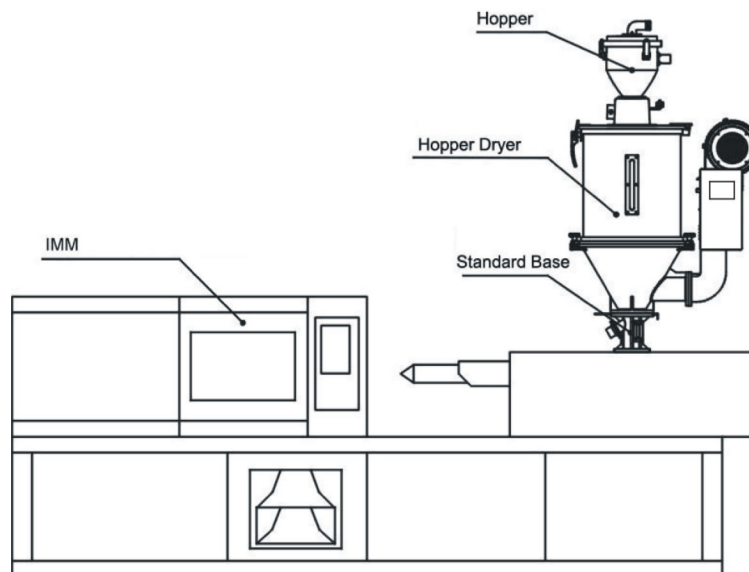

Picture 3-1: Direct Installation

Direct installation type is to mount the hopper dryer directly on the injection molding machine via a standard base.

When using the method to mount the dryer, the equipped standard base must according to material inlet diameter of the molding machine mounting drill holes. Then use the screw to fasten the base and the molding machine inlet.

3.2 Power Connection

- 1) Make sure the voltage and frequency of the power source comply with those indicated on the manufacturer nameplate that attached to the machine.
- 2) Power cable and earth connection should conform to your local regulations.
- 3) Use independent electrical wires and power switch. Diameter of electrical wire should not be less than those used in the control box.
- 4) The power cable connection terminals should be tightened securely.
- 5) This series power adopts three phase five wire, the power (L1,L2,L3) is connected to the firing line, N is connected to the zero wire, and PE is connected to the earth wire.
- 6) Power supply requirements:
Main power voltage: +/- 5%
Main power frequency: +/- 2%
- 7) ***Please refer to the circuit diagram of each model for specific power access specifications.***

Note: Keep 2m distance between the machine and flammable materials.

Note: Before connecting the power, turn the main power switch to "OFF" state, and the heater switch on dryer's control box to "OFF" state.

3.3 The Hopper Dryer Test

After ensuring all the circuits have been connected firmly, turn on the main switch to "ON" status, and observe whether the rotating direction of the blower is same as the arrow indicated direction. If it is not, randomly exchange two of the three power firing lines and connect them firmly.



Picture 3-2: Blower

3.4 Installation of the Options

3.4.1 Installation of Air-Exhaust Filter

If the materials contain dust or to avoid the dust-contain air exhausted by dryer polluting the workshop's environment. Option with air-exhaust filter ADC can filter the exhausted air from the dryer. ADC can reach filter efficiency of 99%.

ADC is installed on air-exhaust elbow of the dryer. Point it to the installed holes then tighten up the screws, use rubber ring to seal the combined place.



Picture 3-3: Left: Air-exhaust elbow of dryer Right: Air-exhaust filter

3.4.2 Suction Box Installation



Picture 3-4: European suction box

When SHD-E is mounted on the floor stand, suction box should be equipped, so as to convey the dried plastic material conveniently. The installation of European suction box and shut-off suction box is simple. Install them at bottom of the hopper, point to the holes and tighten up the screws.



Picture 3-5: Shut-off suction box

3.4.3 Blower Inlet Filter Installation

When dryers in the dust-contain environment or hot air requires high cleanliness, it can option with AIF blower inlet filter.



Picture 3-6: Right: AIF blower inlet filter

Installing AIF at blower inlet port when installing it, firstly loosen screws of the blower inlet screen, take down the screen; Then install the AIF at blower inlet port, point to the holes and tighten up the screws.

3.4.4 Hot Air Recycler Installation

Based on AIF blower inlet filter, using a heat-resistance pipe to connect the hopper exhausting air to AIF. Thus to form a hot air recycler. By recycling the hot air can at most save energy consumption by 40%.



Picture 3-7: HAR Hot air recycler

4. Operation Guide

4.1 Control Panel



Picture 4-1: Control Panel

4.1.1 Panel Operation

- 1) Turn on main switch of control box.
- 2) Press “ON/OFF” key, it starts drying process, indicator turns green.
- 3) Press “ON/OFF” key again, it stops drying process, indicator turns yellow.

4.1.2 Temperature Setting

- 1) The setup number will flicker after pressing "Setting" key, add or decrease temperature by pressing“Up”or “Down”key.
- 2) Press " Setting " key again to confirm the input value.

4.1.3 Temperature Lock

- 1) Press “menu” key for 2 seconds, it displays “TIME”.
- 2) Press “Up” key repeatedly, till it display “LOCK”;
- 3) Press “Setting” key, the set value flickers, press “Up”or “Down” key to select “YES”(lock temperature setting) and “NO” (don’t lock).
- 4) Press “Setup” key to confirm the input value.

- 5) Press “Menu” key to return operation menu.

Notes: When “LOCK” is set as “YES, temperature setting value will be locked which not accessible to change.



4.1.4 PID Setting

- 1) Press both “Menu” and “Down” keys for 3 seconds, it shows “P” (proportion) setting;
- 2) Press “Setting” key, the set value flickers, then press “Up” or “Down” key to add or decrease the value.
- 3) Press “Setting” key to confirm the input value.
- 4) Press “Up” key again and again, it displays “I” (integral time) and “D” (differential time) setting accordingly.
- 5) Repeat above step 2 and step 3, input and confirm related parameters.
- 6) Press “Menu” key, it returns operation menu.

Notes: The PID parameter will directly influence the effect of temperature control, please be careful to set the value!

Table 4-1: PID Setting Parameter

Parameters	Codes	Factory Default
Proportion	P	5
Integral time	I	200
Integral time	D	30
Over-temp alarm	OTP	15°C
Control cycle	HCLE	15
Blower delay	FDLY	180
Temp. unit	UNIT	°C

4.1.5 Intermittent Operation Setting

- 1) Hold “Menu” for about 2 secs. to set current time and week. Press “Up” or “Down” key to set start/stop function of AUTO timer, the time for RONE intermittent operation, the OFF time of ROFF intermittent operation, the ON time of RON intermittent operation.

4.1.6 One-week Timing Setting

- 1) After current time is set, hold “menu” for about 5 secs, press “Up” or “Down” key to set OFF1 (Mon. off time), OFF2(Tues. off time), OFF3 (Wed. off time), OFF4(Thur. off time), OFF 5(Fri. off time), OFF6(Sat. off time), OFF7(Sun.off time).
- 2) Hold “Menu” for about 7S, press “Up” or “Down” key to set ON1(Mon. start time), ON2(Tues. start time), ON3(Wed. start time), NO4(Thur. start time), ON5(Fri. start time), ON6(Sat. start time), ON7(Sun. start time).

4.1.7 Communication Setting (optional functions)

- 1) Press both “Menu” key and “Up” key for 3 seconds, it displays “PRO” (communication protocol) setting.

Notes: Communication protocol is fixed to Modbus RTU protocol—“RTU”.

- 2) Press “Up” key to enter “ID” (communication address) setting;
- 3) Notes: The communication address of every controller in the same system must be the only one, no repeat use. In principle: communication address of hopper 1 is 1, communication address of hopper 1 is 2, and so on.

- 4) Press “Setup” key, the set value flickers, then press “Up” or “Down” key to add or decrease the value.
- 5) Press “Setting” key to confirm the input value;
- 6) Press “Up” key again and again, it displays “Baud” and “PAR” settings, (as below)
- 7) Repeat step 3 and step 4, then confirm the related input parameters.
- 8) Press “Menu” key to return operation menu.

Table 4-2: Communication Setting Parameter

Communication Parameters	Communication Codes	Factory Default
Communication Protocol	PRO	RTU
Communication Address	Id	1(current address)
Baud Rate	Baud	19.2K
PAR	PAR	none
Data Length	Data	8
Stop Bit	Stop	1

4.1.8 Operation Flow

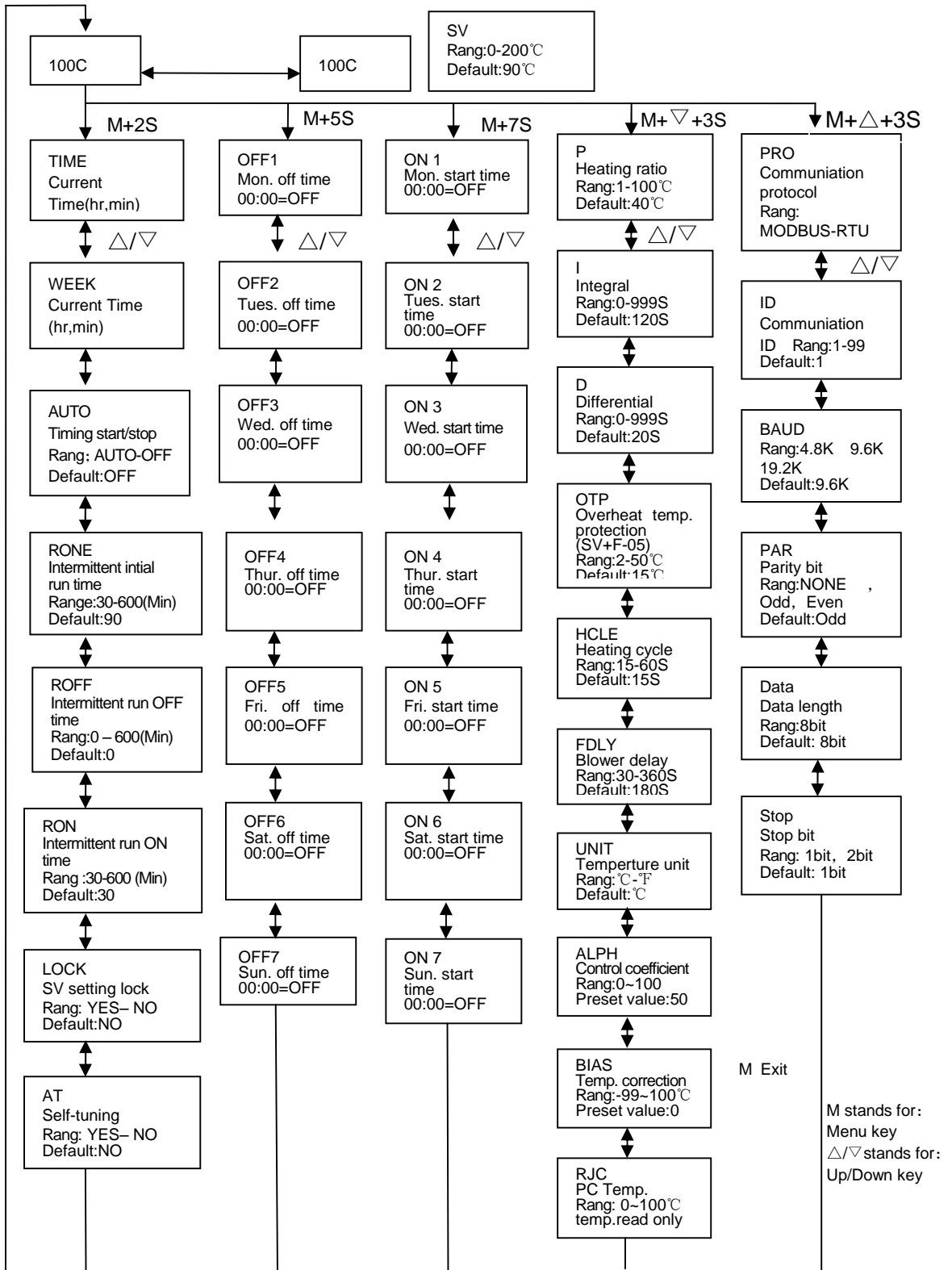

4.1.9 Wrong Codes Remark



Table 4-3: Error Code Description

Wrong Codes	Remark
bR	Thermocouple break
oH	Overheat
REV	Temperature sensor reversely connected
oL	Overload
bAT	Battery error
EGO	EGO Over-temp
xATx	Auto-turning error
LT	Low temperature
HT	Heating alarm

5. Maintenance and Repair

5.1 Blower

- 1) Clean the blower regularly (especially the air inlet path) to remove the dust on surface.
- 2) Eliminate the blower's dirt regularly to avoid the blower damage.



Note: No need for regular inspection because all the electrical parts in the control unit are fixed tightly!

6. Troubleshooting

Table 6-1: Common Faults and Troubleshootings

Fault	Possible Reasons	Solution
Blower rotating on the contrary with arrow	Blower circuit connection reverse phase.	Exchange two of the electrical wires.
Blower not turning	<ol style="list-style-type: none"> 1. Motor fault. 2. Failures of solenoid switch. 	<ol style="list-style-type: none"> 1. Check and change. 2. Change or repair.
Blower not rotating and not heating	<ol style="list-style-type: none"> 1. Overload jumped. 2. Transformer fault. 3. Fuse melted. 4. Power supply fault. 	<ol style="list-style-type: none"> 1. Check and change. 2. Check and change. 3. Check and change. 4. Check if lack of phase.
No temperature for blower runs while	<ol style="list-style-type: none"> 1. Lead sheet of heater pipe melted. 2. Magnetic switch fault. 3. Heater fault. 4. Controller fault. 5. Thermocouple fault. 	<ol style="list-style-type: none"> 1. Check and change. 2. Check and change. 3. Check and change. 4. Check and change. 5. Change.
The blower can run but temperature is too low	<ol style="list-style-type: none"> 1. Lead sheet of heater pipe fault. 2. EGO broken. 3. Magnetic switch is lack of phase. 4. Controller is damaged . 	<ol style="list-style-type: none"> 1. Check and change. 2. Check or re-set. 3. Check and change. 4. Change the temperature controller.
The blower can run but temperature is too high	<ol style="list-style-type: none"> 1. Hot-air pipe is jam. 2. Controller is fault. 3. Magnetic switch contacts stuck up. 	<ol style="list-style-type: none"> 1. Cleaning. 2. Change the controller or adjust PID. 3. Change.



Notes: Before inspecting or changing spare parts, make sure the main switch should be off.